

NOTES

24" MAINTENANCE CLEARANCE AROUND SYSTEM.

36" CLEARANCE IN FRONT OF DISCONNECT PANEL.

ELECTRICAL PANELS/VFD'S FIELD INSTALLED BY OTHERS.

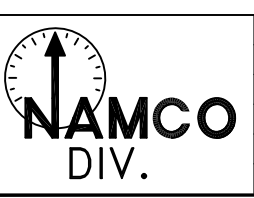
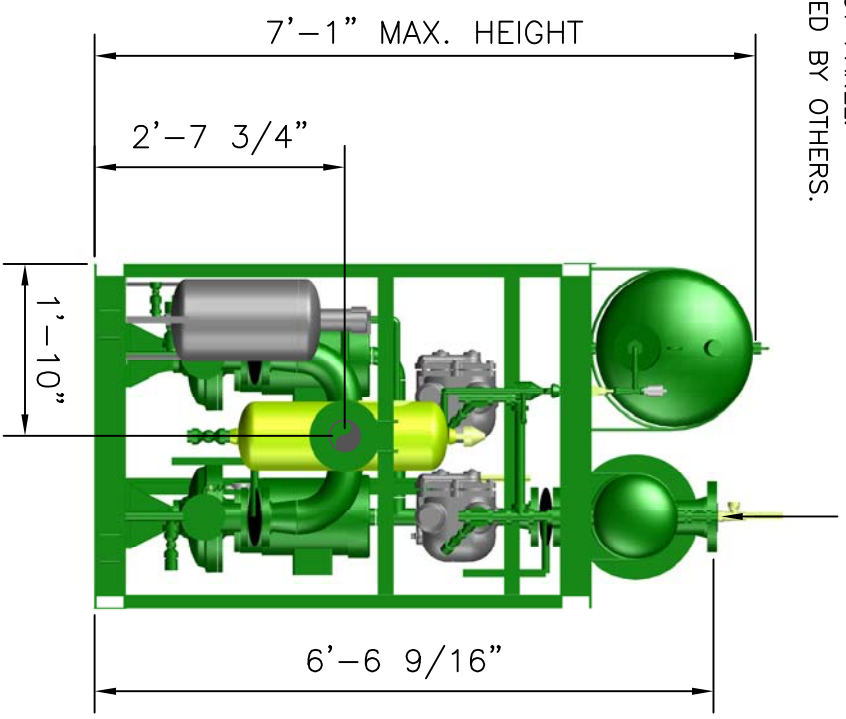
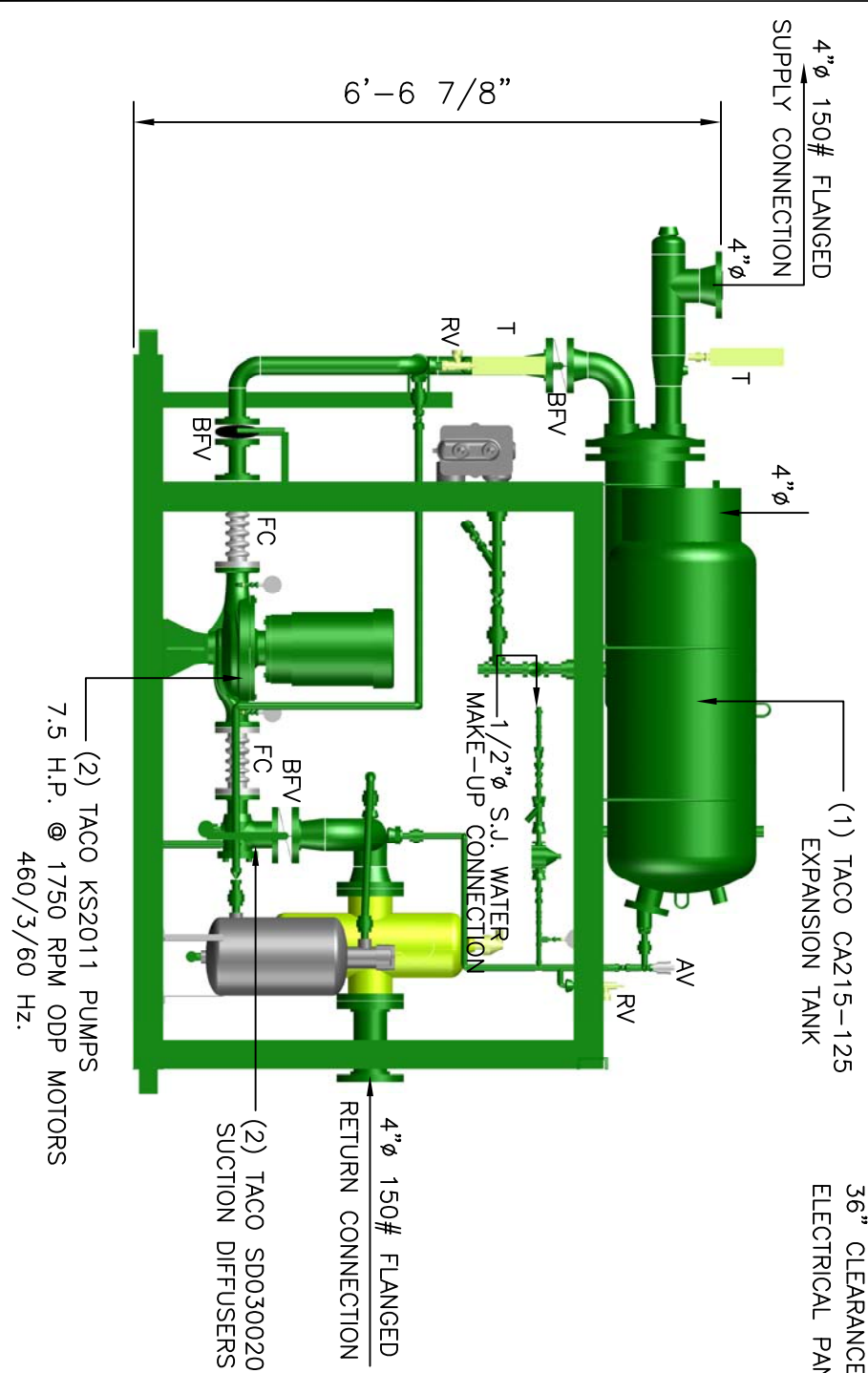

NO.	REVISION	DATE	BY	APR

© COPYRIGHT THIS DRAWING IS THE PROPERTY OF NAMCO DIV. OF JOHN R. NEAL & ASSOCIATES INC. DALLAS, TEXAS ITS USE WITHOUT THE EXPRESS WRITTEN PERMISSION IS PROHIBITED.

ENG. RECORD	DATE
DRAWN BY RDO	04/14/15
CHECKED	
APPROVED	08/04/15
APPROVED	
SCALE NONE	

HEATING HTM	
HTM150-30-S HEAT TRANSFER MODULE	
JOB NO.	N-3209
DRAWING NO.	15-00020
REV.	2