

(2) TACO 1935 PUMP
 7.5 H.P. @ 3450 RPM NEMA 56C MOTORS
 460/3/60 Hz.
 4" Ø 3-WAY VALVE
 WITH ACTUATOR

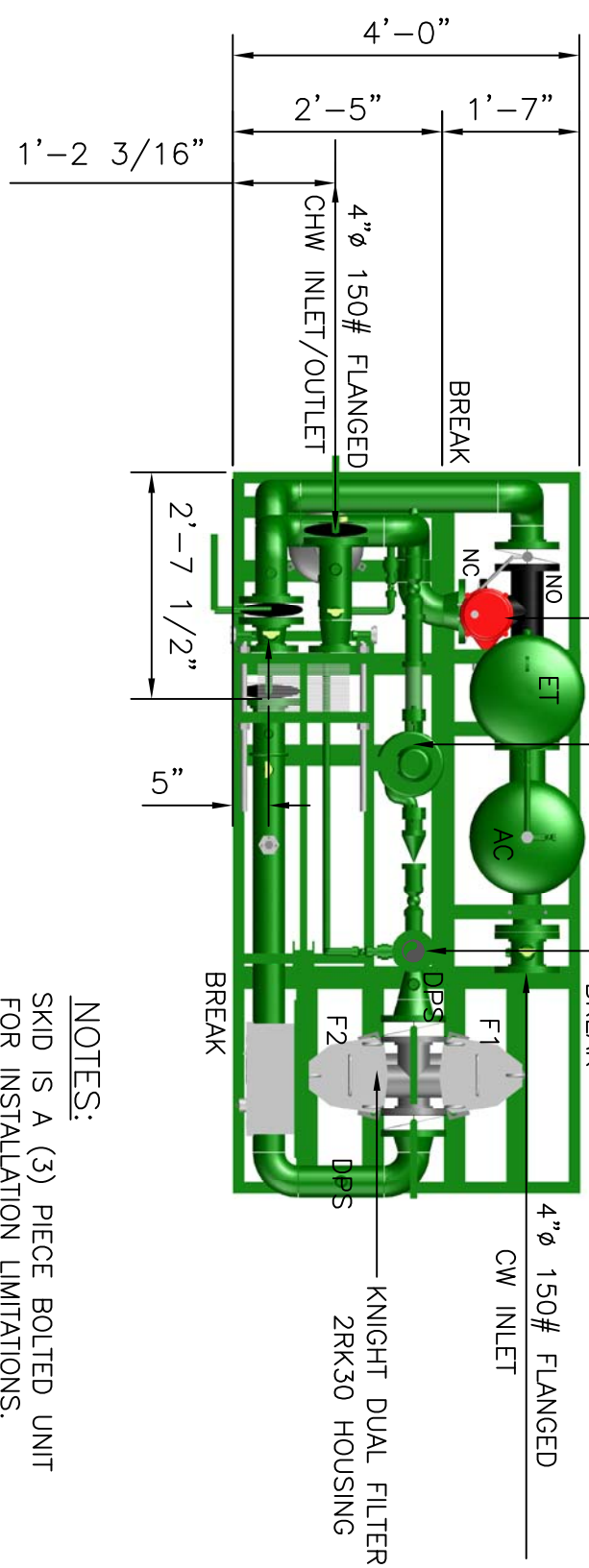

NOTES:
 SKID IS A (3) PIECE BOLTED UNIT
 FOR INSTALLATION LIMITATIONS.
 TS = TEMPERATURE SENSING TAP
 DPS = DIFFERENTIAL PRESSURE SENSING TAP

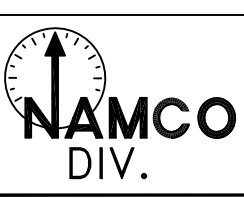
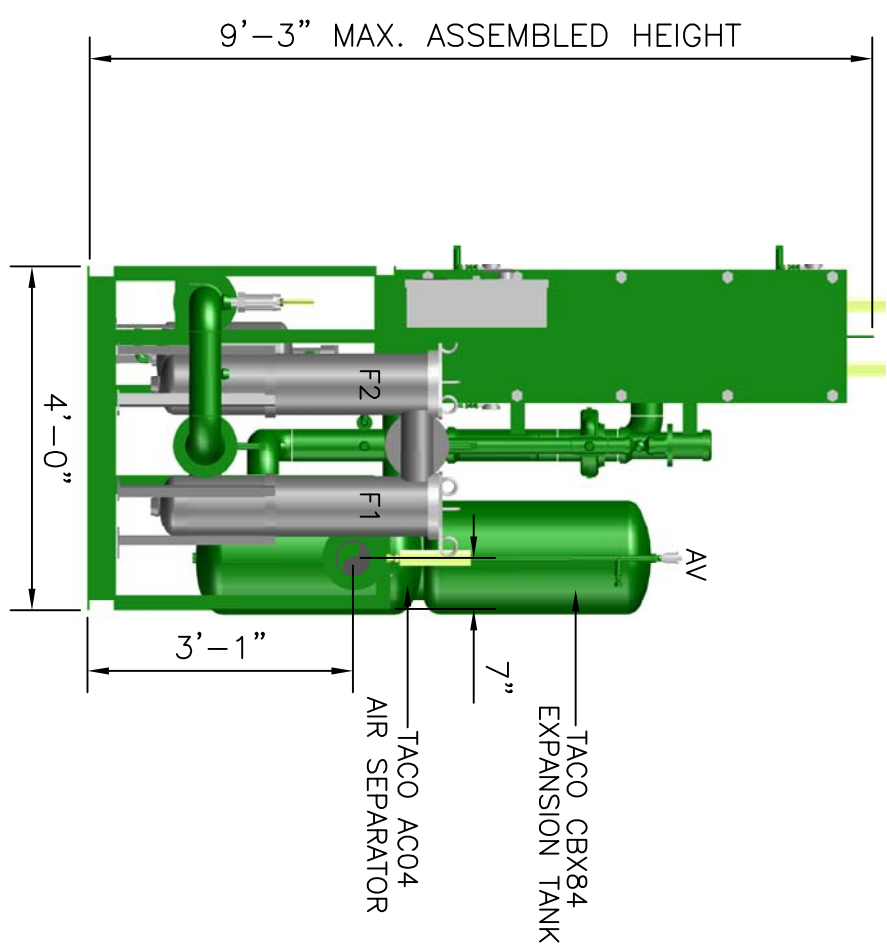
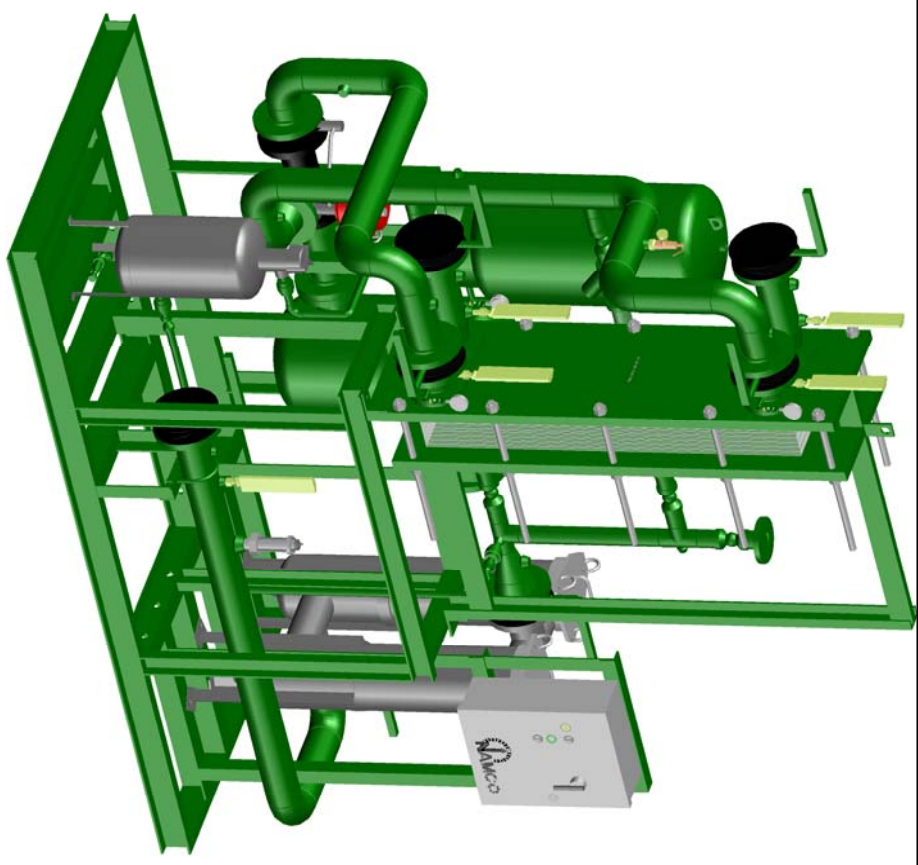
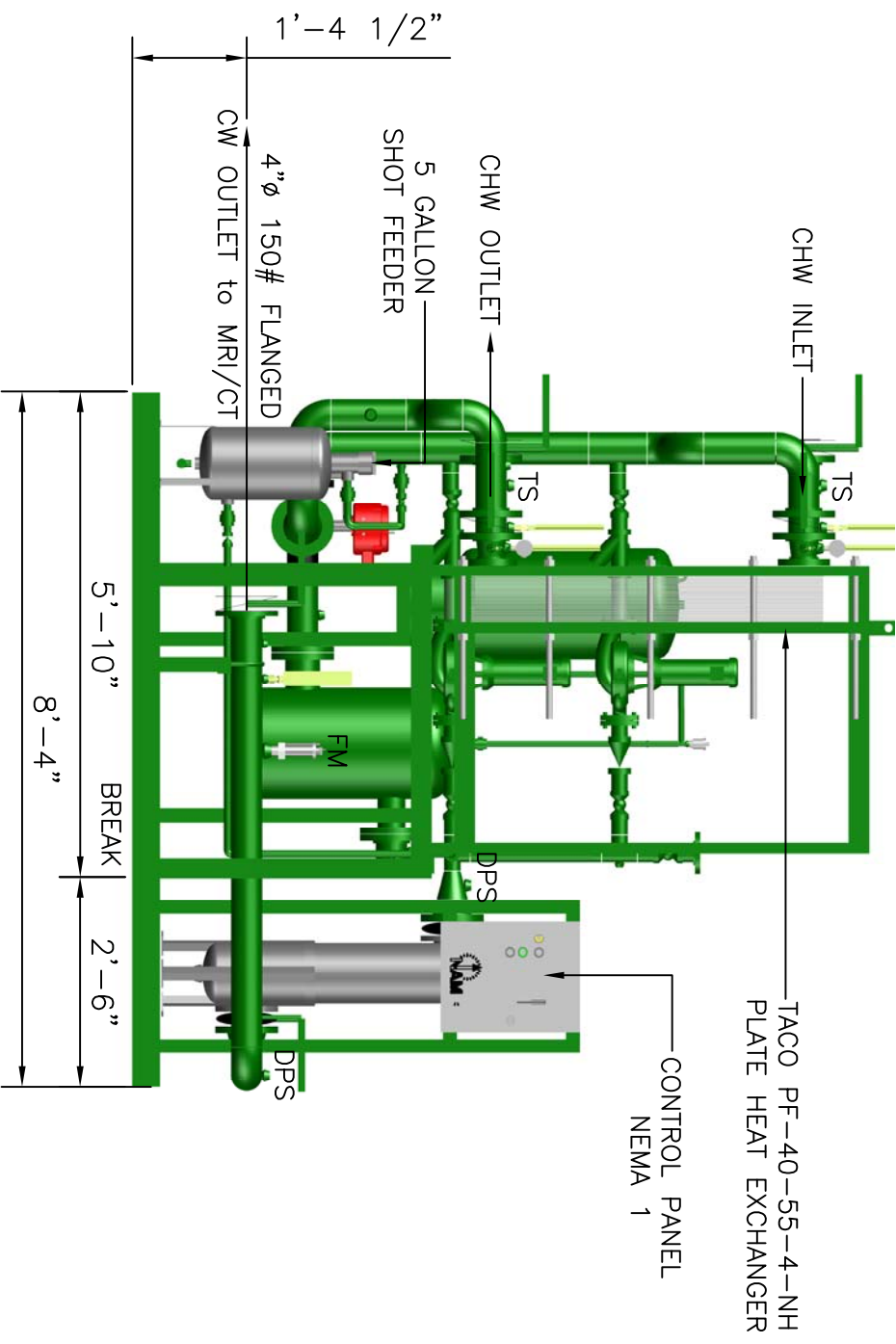

NO.	REVISION	DATE	BY	APR

© COPYRIGHT
 THIS DRAWING IS THE PROPERTY OF
 NAMCO DIV. OF JOHN R. NEAL &
 ASSOCIATES INC. DALLAS, TEXAS ITS
 USE WITHOUT THE EXPRESS WRITTEN
 PERMISSION IS PROHIBITED.
HTM180-35L

ENG. RECORD	DATE
DRAWN BY RDO	07/13/15
CHECKED	
APPROVED	9/04/15
APPROVED	
SCALE NONE	

LIQUID/LIQUID HEAT EXCHANGE SYSTEM	
JOB NO.	N-3212
DRAWING NO.	15-00031
REV.	0