

(3) GRUNDFOS CRN45-2-2 PUMPS
15 H.P. @ 3500 RPM TEFC/PE MOTORS
460/3/60 Hz.

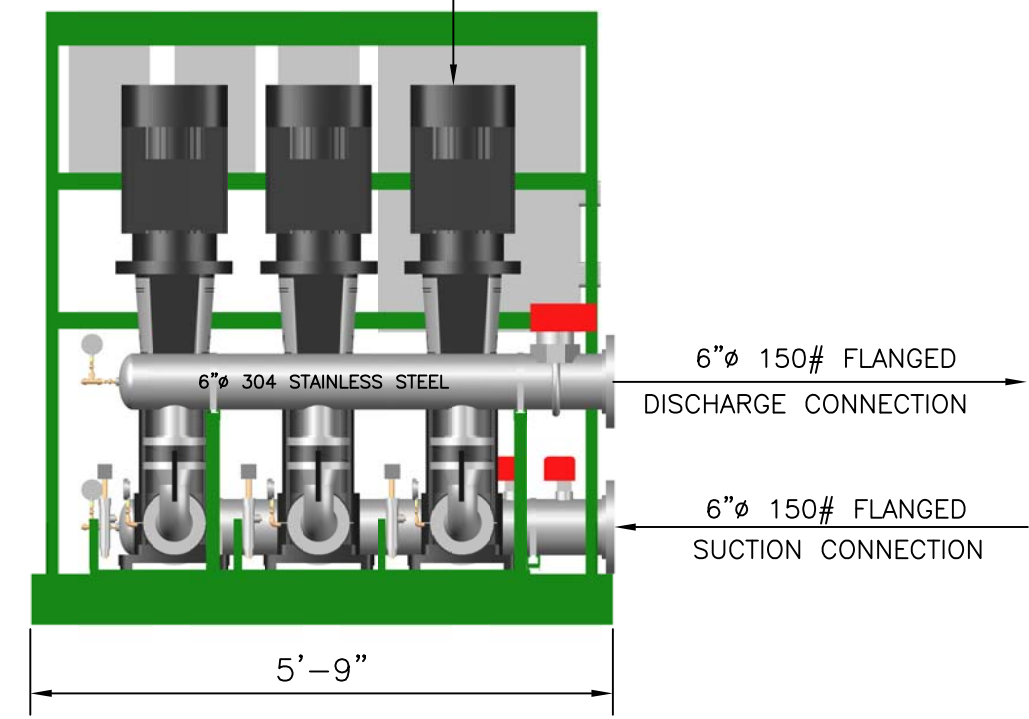
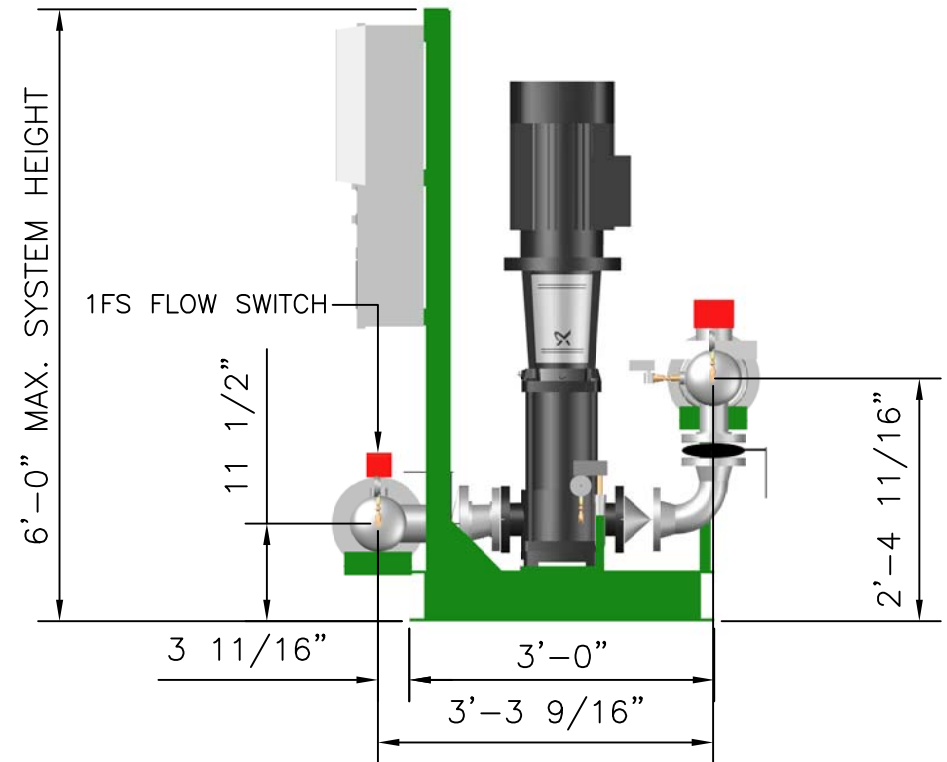

<p>© COPYRIGHT THIS DRAWING IS THE PROPERTY OF NAMCO DIV. OF JOHN R. NEAL & ASSOCIATES INC. DALLAS, TEXAS ITS USE WITHOUT THE EXPRESS WRITTEN PERMISSION IS PROHIBITED.</p>		<p>DATE 09/02/15</p>	<p>TRIPLEX VFD BOOSTER SYSTEM</p>
<p>ENG. RECORD DRAWN BY RDO</p>	<p>CHECKED</p>	<p>APPROVED 09/04/15</p>	<p>JOB NO. N-3211</p>
<p>APPROVED</p>	<p>SCALE NONE</p>	<p>DRAWING NO. 15-00039</p>	<p>REV. 0</p>
<p>NO. REVISION</p>	<p>DATE</p>	<p>BY</p>	<p>APR</p>
<p>NAMCO DIV.</p>			